



INSTALLATION INSTRUCTIONS HIGH OUTPUT TRIPLE RAD FAN ASSEMBLY PART # 16839

Please read these instructions completely before beginning installation

KIT CONTENTS

QTY.	DESCRIPTION	QTY.	DESCRIPTION
1	Fan Shroud Assembly	16	1/4-20 x 3/4" Hex Bolts
4	Angle Brackets	16	1/4-20 Nyloc Nuts
1	Rubber Fan Shroud Seal	32	1/4 Flat Washers

TOOLS NEEDED

- 7/16" Open End Wrench
- 7/16" Socket and Ratchet
- Wire Stripper
- Crimping Tool

Diagram #1

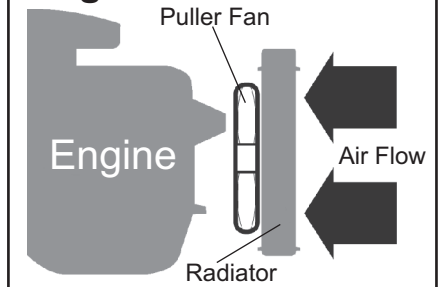

IMPORTANT

This fan assembly is designed for PULLER APPLICATIONS **ONLY** Engine side of radiator. (See Diagram #1)

Diagram #2

MOUNTING OPTIONS

Down Flow Radiator

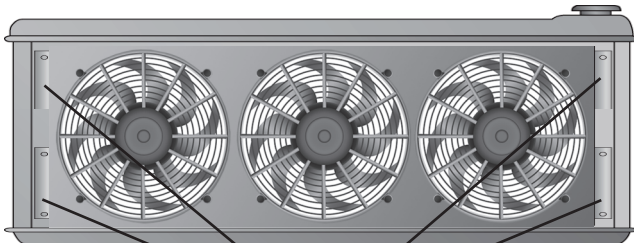

Brackets Provided

Note: For illustration purposes only. Actual part may differ

Cross Flow Radiator

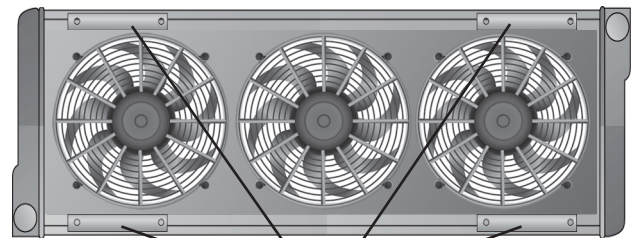

Brackets Provided

Shroud should be mounted tight against radiator to minimize air leaks that would reduce efficiency.

Diagram #3

Flush Mount

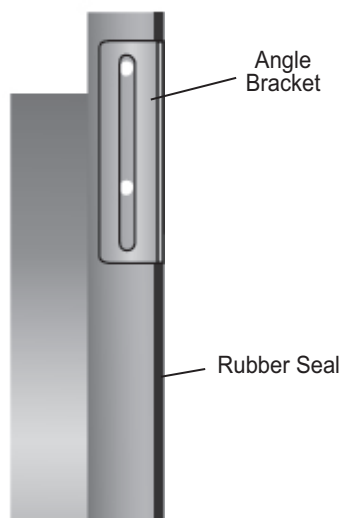
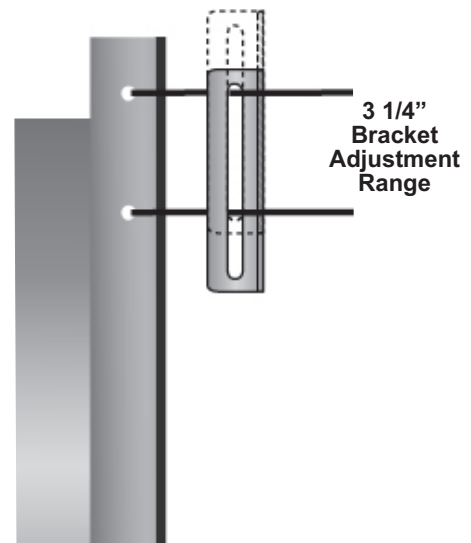

Diagram #4

Adjustment Range



MOUNTING

1. Install the Rubber Fan Shroud Seal.
2. Position the electric fan in the desired location. Taking the Angle Brackets supplied, determine the best locations for a good rigid mount. (See Diagram #2)
3. Take the four Angle Brackets, 1/4" Hex Bolts, Washers and Nyloc Nuts provided and attach brackets to the fan shroud in the desired location.
4. In some applications where the radiator flange is not right up against the fan shroud, longer bolts can be used to space Angle Brackets properly. Hardware not included. (See Diagram #6)
5. Using the remaining 1/4" Hex Bolts, Washers and Nyloc Nuts provided, mount the Fan Shroud Assembly to the radiator. (See Diagram #5)

Note: In some cases the radiator flange may have to be drilled for proper alignment.

Diagram #5

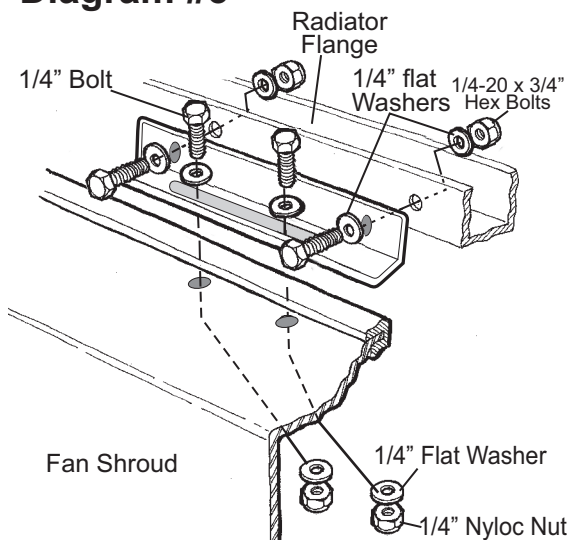
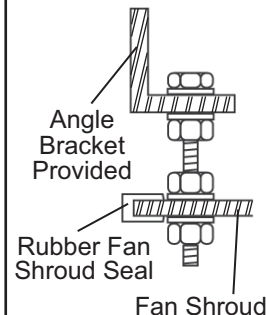

Diagram #6

OPTIONAL MOUNTING



WIRING OPTIONS

IMPORTANT: Due to the high amperage of each individual RAD fan on the Dual RAD Fan Assembly, each fan MUST be switched* individually. Failure to use two different switching devices could cause damage to your vehicle and/or your new Electric Fan Assembly.

* Switched - Utilizing an automotive rated thermostat or manual switch

There are a few options on how to activate (turn on) your new Electric Fan Assembly.

1. Manual Switch - Install a switch in the passenger compartment and turn on Electric Fan as desired.
2. Electric Fan Thermostat Switch
 - A. Adjustable Thermostat - Allows an adjustment range for you to determine optimal turn on temperature.
 - B. Pre Determined Temperature - Thermostat has a pre determined temp. from the factory that determines turn on temp.

We recommend using two thermostats to activate Fan #1 at an earlier temperature than Fan #2 (we recommend having fan 2 & 3 use the same thermostat). This will help spread the major amp draw on your vehicles electrical system. Please visit www.derales.com for available thermostat options or visit your local retailer. (See Diagram #7)

Important: When purchasing a thermostat always consider the maximum amp draw. Some thermostats are not designed to properly handle 25 amps.

Note: When installing the Electric Fan with a Thermostat always follow manufacturer's instructions for specific details.

WIRING INSTALLATION USING RELAY(S) (NOT SUPPLIED)

Repeat for all 3 fans. Fan #1, Fan #2 and Fan #3 (Fans #2 & #3 can use the second relay, See Diagram #7)

RED Wire - Attach to the Positive side of Battery (+)

BLACK Wire - Attach to a good Chassis ground (-)

ORANGE Wire - Attach to the Red Positive Electric Fan Lead (Fan +)

YELLOW Wire - Attach to (+) 12V Switched Power (Thermostat or Manual Switch)

GREEN Wire* - (OPTIONAL) Attach to the Positive feed from the A/C Clutch

*This wire will allow you to turn on the Electric Fan every time the vehicles air conditioning is turned on. If you do not wish to use this option, please disregard the Green wire.

ELECTRIC FAN

Red Wire - (+) Positive Fan lead Attach to the ORANGE wire coming from the relay harness

BLACK Wire - (-) Negative Fan Lead Attach to a good Chassis ground (See Diagram #7)

Diagram #7

Wiring Diagram Using Relays (Part # 16763 Not Supplied)

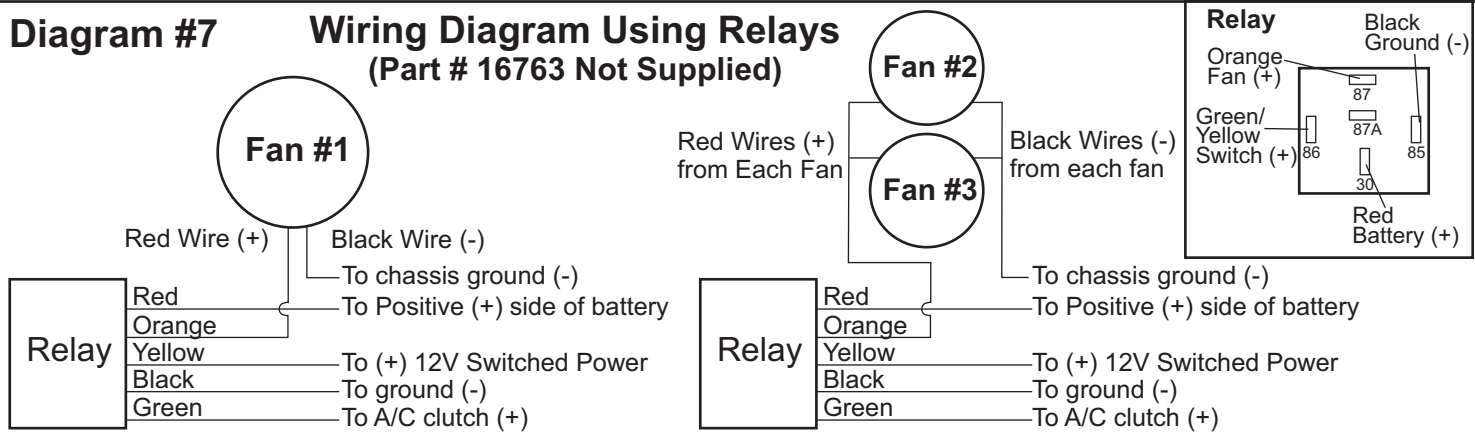

Warning: Installation of accessories should only be undertaken by those with mechanical knowledge and are familiar with working on vehicles. Always use eye protection (goggles, safety glasses or shield). Park the vehicle in a well lit area, on level ground and apply the parking brake. Only work on a cold vehicle that has been sitting overnight, failure to do so will result in severe burns and injury. Before starting the vehicle, make sure no tools or any other items are left under hood that could interfere with or be drawn into moving parts of the engine. Failure to follow instructions can lead to severe damage and personal injury.