



# INSTALLATION INSTRUCTIONS HIGH OUTPUT DUAL RAD FAN ASSEMBLY PART # 16843

Please read these instructions completely before beginning installation

### KIT CONTENTS

QTY.	DESCRIPTION	QTY.	DESCRIPTION
1	Fan Shroud Assembly	16	1/4-20 x 3/4" Hex Bolts
4	Angle Brackets	16	1/4-20 Nyloc Nuts
1	Rubber Fan Shroud Seal	32	1/4 Flat Washers

### TOOLS NEEDED

- 7/16" Open End Wrench
- 7/16" Socket and Ratchet
- Wire Stripper
- Crimping Tool

### Diagram #1

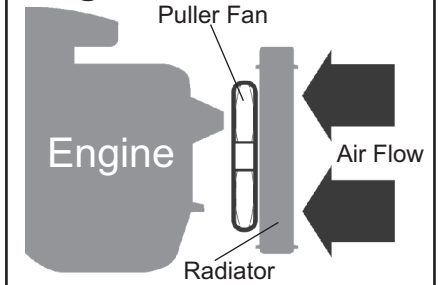

### IMPORTANT

This fan assembly is designed for PULLER APPLICATIONS ONLY Engine side of radiator. (See Diagram #1)

### MOUNTING OPTIONS

#### Diagram #2

Note: For illustration purposes only.  
Actual part may differ

**Down Flow Radiator**

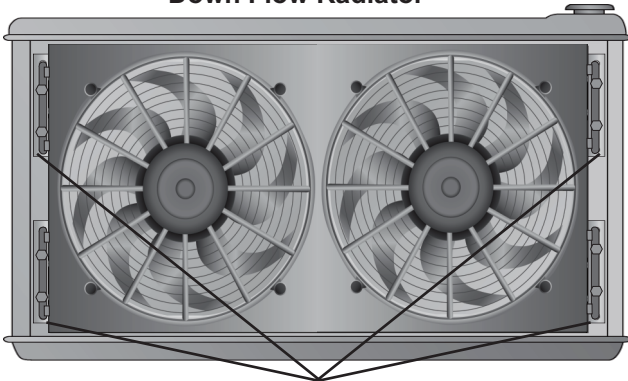

Brackets Provided

Shroud should be mounted tight against radiator to minimize air leaks that would reduce efficiency.

**Cross Flow Radiator**

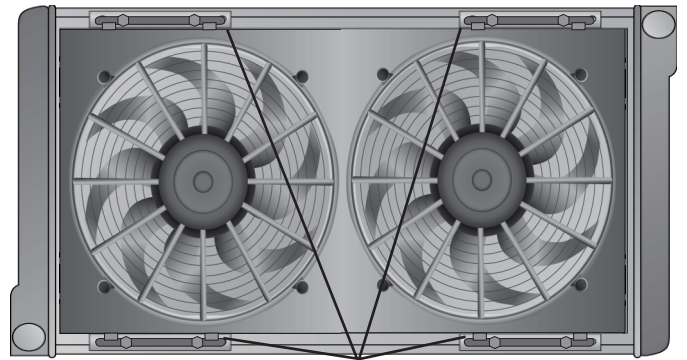

Brackets Provided

#### Diagram #3

**Option 1  
Flush Mount**

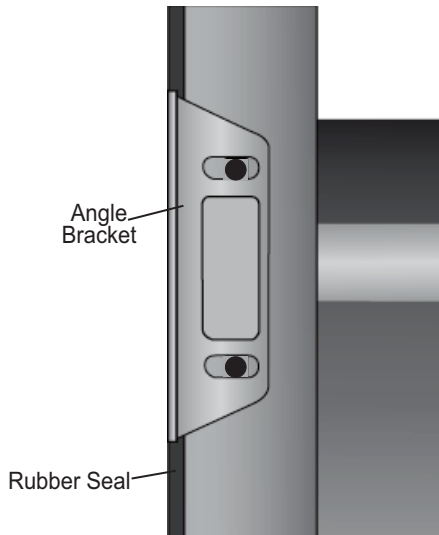

**Option 2  
Recessed Mount**

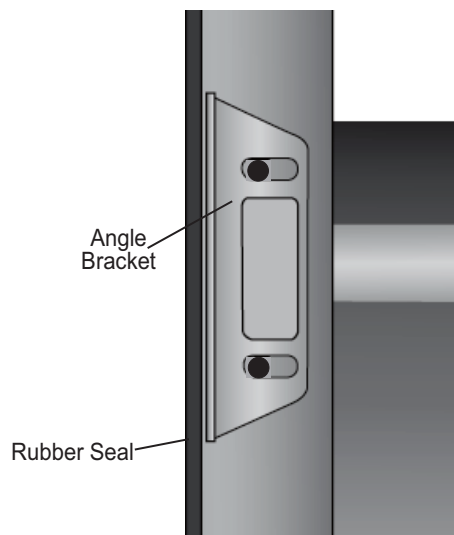

## INSTALLATION

- Using a table or workbench, lay the Electric Fan Assembly on a flat surface, Electric Fan facing down.
- Take the supplied Rubber Fan Shroud Seal and install it onto the bottom edge of the Fan Shroud Assembly. (See Diagram #4)
- Identify the four Angel Brackets, 1/4-20 x 3/4" Hex Bolts, 1/4" Flat Washers & 1/4-20 Lock Nuts.
- Attach the Angle Brackets to the Shroud using two bolts per bracket. (See Diagram #5)  
**Note:** In some applications where the radiator flange is not right up against the fan shroud, longer bolts can be used to space the Angle Brackets. (See Diagram #6) Hardware not included!
- Position the Electric Fan Assembly against the radiator in the desired location.
- Using the remaining 1/4-20 x 3/4" Hex Bolts, 1/4" Flat Washers & 1/4-20 Lock Nuts, attach the Electric Fan Shroud Assembly to the radiator. (See Diagram #5)  
**Note:** In some cases the radiator flange may have to be drilled for proper alignment.

**Diagram #4**

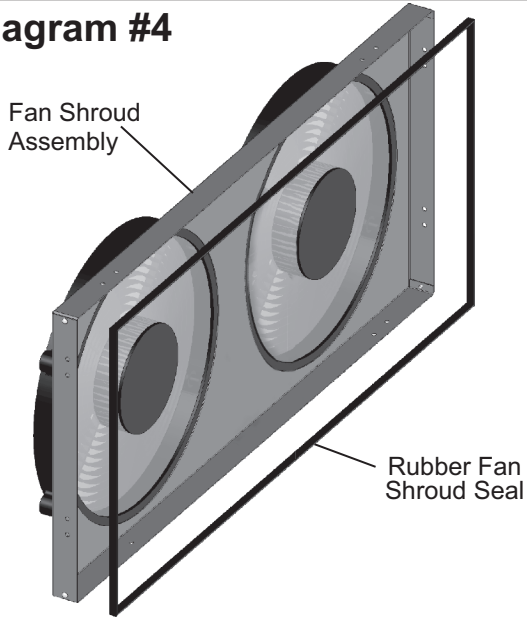

**Diagram #5**

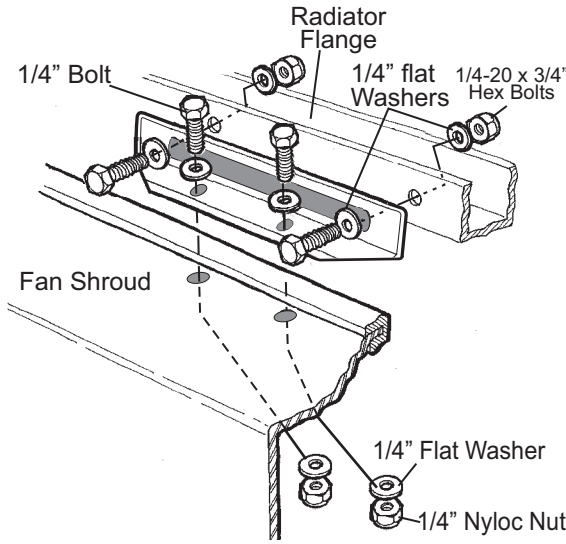

**Diagram #6**

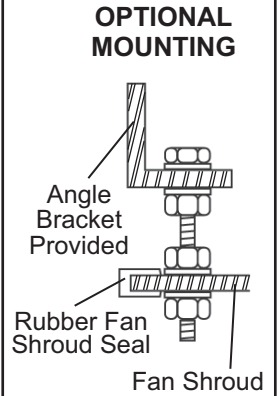

## WIRING

**Important:** The Electric Fan Assembly is built using a High Output two speed motor. If you choose to operate the fan using both speeds, two switching devices are recommended. (See Diagram #7 & 8)

### WIRING DIAGRAM WITH RELAY (RELAY NOT SUPPLIED)

**Diagram #7 High Speed Only**

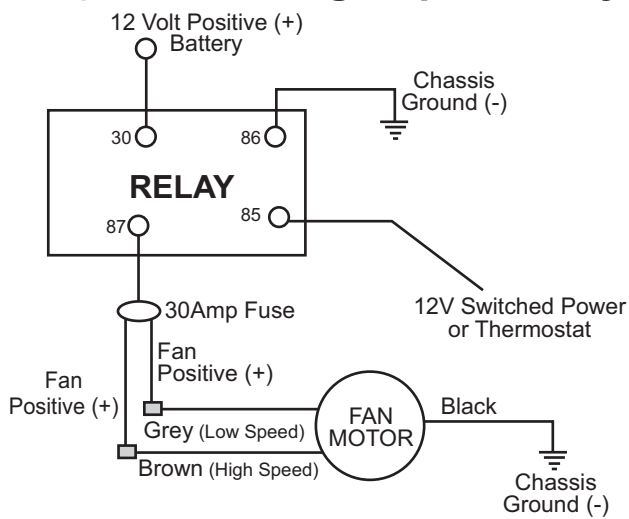

**Diagram #8 Low & High Speeds**

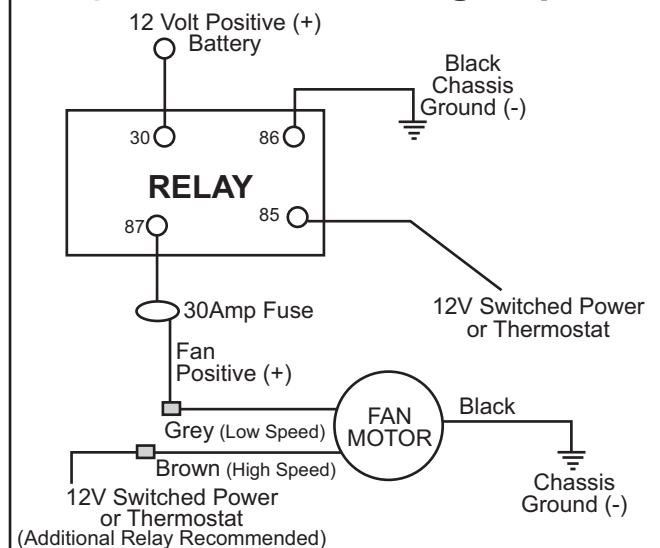

(Wiring Diagram Continued on Page 3)

## FAN WIRE COLOR DESIGNATIONS

**Black Wire** - Ground (-)

**Grey Wire** - Low Speed 12V positive (+)

**Brown Wire** - High Speed 12V positive (+)

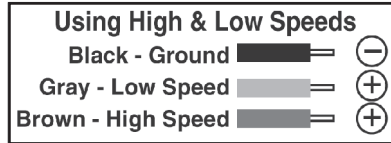

## STANDARD WIRING

**Using High Speed Only** - Connect both Grey and Brown wires together to the same 12V positive (+) source

**Using Both Low and High Speeds** - Connect Grey wire to Switch #1, 12V positive (+) source.

- Connect Brown wire to Switch #2, 12V positive (+) source.

**Important: Low speed must be activated prior to high speed activation**

## WIRING OPTIONS

**IMPORTANT:** Due to the high amperage of each individual RAD fan on the Dual RAD Fan Assembly, each fan **MUST** be switched\* individually. Failure to use two different switching devices could cause damage to your vehicle and/or your new Electric Fan Assembly.

\* Switched - Utilizing an automotive rated thermostat or manual switch

There are a few options on how to activate (turn on) your new Electric Fan Assembly.

1. Manual Switch - Install a switch in the passenger compartment and turn on Electric Fan as desired.
2. Electric Fan Thermostat Switch
  - A. Adjustable Thermostat - Allows an adjustment range for you to determine optimal turn on temperature.
  - B. Pre Determined Temperature - Thermostat has a pre determined temp. from the factory that determines turn on temp.

We recommend using two thermostats to activate Fan #1 at an earlier temperature than Fan #2. This will help spread the major amp draw on your vehicles electrical system. Please visit [www.derales.com](http://www.derales.com) for available thermostat options or visit your local retailer.

**Important:** When purchasing a thermostat always consider the maximum amp draw. Some thermostats are not designed to properly handle 25 amps.

**Note:** When installing the Electric Fan with a Thermostat always follow manufacturer's instructions for specific details.

## WIRING INSTALLATION USING RELAY(S) (DERALE PART # 16763 NOT SUPPLIED)

Repeat for both Fan #1 and Fan #2.

**RED Wire** - Attach to the Positive side of Battery (+)

**BLACK Wire** - Attach to a good Chassis ground (-)

**ORANGE Wire** - Attach to one low / high speed wire.

**YELLOW Wire** - Attach to (+) 12V Switched Power (Thermostat or Manual Switch)

**GREEN Wire\*** - (OPTIONAL) Attach to the Positive feed from the A/C Clutch

\*This wire will allow you to turn on the Electric Fan every time the vehicles air conditioning is turned on. If you do not wish to use this option, please disregard the Green wire.

## **Questions?**

If using one of our Fan Controllers, Please contact tech support at 1-800-421-6288 for further clarification.

(Page 3)

**Warning:** Installation of accessories should only be undertaken by those with mechanical knowledge and are familiar with working on vehicles. Always use eye protection (goggles, safety glasses or shield). Park the vehicle in a well lit area, on level ground and apply the parking brake. Only work on a cold vehicle that has been sitting overnight, failure to do so will result in severe burns and injury. Before starting the vehicle, make sure no tools or any other items are left under hood that could interfere with or be drawn into moving parts of the engine. Failure to follow instructions can lead to severe damage and personal injury.