



INSTALLATION INSTRUCTIONS OIL FILTER RELOCATION KIT PART # 15780

Please read these instructions completely before beginning installation

KIT CONTENTS

QTY.	DESCRIPTION	QTY.	DESCRIPTION	QTY.	DESCRIPTION
1	Spin-On Adapter	1	3/4-16 Filter Nipple	1	3/4-16 Hex Cast Nut
1	Adapter Plate	10ft.	1/2" Hose	1	13/16-16 Hex Cast Nut
1	Side Ports Filter Mount	2	1/2" NPT Plug	1	18mm x 1.5 Hex Cast Nut
1	O-ring (Spin-On Adapter)	4	1/2" NPT x 1/2" Hose Barb	1	20mm x 1.5 Hex Cast Nut
1	O-ring (Adapter Plate)	4	Hose Clamps	1	22mm x 1.5 Hex Cast Nut
1	Snap Ring	3	#14 Sheet Metal Screws		

TOOLS NEEDED

7/8" Open End Wrench
Standard Screw Driver
1/8" Allen Wrench
Drill
3/16" Drill Bit
Thread Sealant Tape

IMPORTANT

The Adapter Plate & O-ring are designed to fit vehicles with a 3 1/2" filter landing. Primarily 1963-2007 GM SB & BB V-8 engines.

There are 5 supplied Sleeve Nuts in this kit. Only 1 Sleeve Nut will be used for your application.

PRE-INSTALLATION

1. Remove the factory oil filter and clean the oil filter landing surface on the engine block.
2. Using Thread Sealant Tape or suitable sealant, install two 1/2" NPT x 1/2" Hose Barb fittings onto the correct "IN" and "OUT" ports on the Filter Mount.
3. Take the two 1/2" NPT Plugs provided, using Thread Sealant Tape or suitable sealant; install them in the remaining ports on the Filter Mount.
4. Take the remaining two 1/2" NPT x 1/2" Hose Barb fittings, using Thread Sealant Tape or suitable sealant; install them onto the Spin-on Adapter.

SELECTING COMPONENTS

To easily select the correct components for your application, follow the steps below. Then proceed to the INSTALLATION sections.

Selecting the Spin-on Adapter and/or Adapter Plate

1. Using a rag, clean the oil filter landing on the engine.
2. Take the supplied Spin-on Adapter and Adapter Plate.
3. To determine if your application uses the supplied Adapter Plate, first hold the Adapter Plate up to the oil filter landing on the engine block. The casting needs to seat directly onto the landing without obstruction. If the Adapter Plate is too large, then disregard the Adapter Plate and O-ring. (See Diagram #2)
4. Take the supplied Spin-On Adapter and hold it up the oil filter landing on the engine block. The casting needs to seat directly onto the landing without obstruction.

Selecting the Cast Nut

1. Take the 5 supplied Cast Nuts, try and screw each Cast Nut onto the filter nipple on the engine block until the correct size will completely thread onto the nipple. Once you have located the correct Cast Nut, disregard the remaining 4 Cast Nuts.
2. Take the Cast Nut and slide it into the Spin-on Adapters hex feature. Cast Nut will only install correctly in one direction. (See Diagram #1)
3. Take the supplied Snap Ring and carefully install into the snap ring groove of the casting making sure it is securely fastened. (See Diagram #1)

Warning: It is recommended that you wear the proper eye protection when installing Snap Ring.

(Continues on Page 2)

Diagram #1

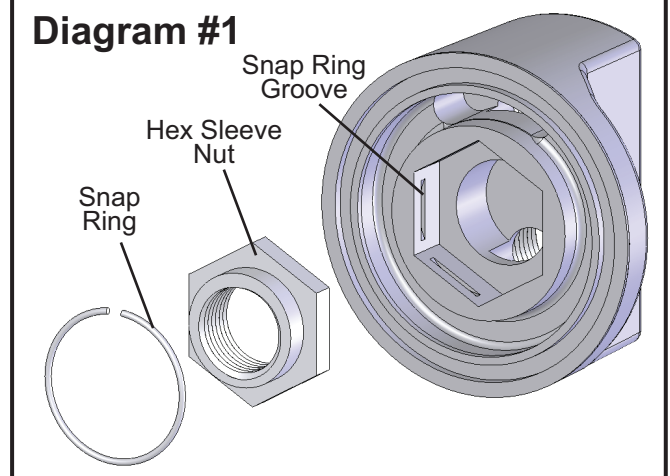
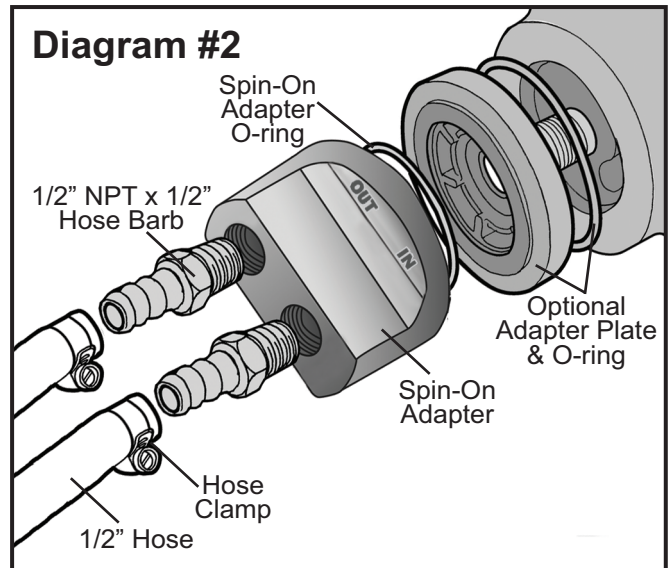

Diagram #2



SPIN-ON ADAPTER INSTALLATION

1. Apply a light coat of oil onto the O-ring(s).
2. Take the O-ring and install into the groove on the Spin-On Adapter and Adapter Plate (if used).
3. Install onto the engine. (See Diagram #2)
4. Hand Tighten with the same force used in tightening a factory oil filter.

OIL FILTER CHART

BRAND	PART #
AC	PF2
Fram	PH8A
Motorcraft	FL1A
Purolator	PER1A

FILTER MOUNT INSTALLATION

1. Choose a convenient location for the Ports-Up Filter Mount. Make sure there is enough space for future servicing of the oil filter. Suggested Locations: Firewall, Radiator Support, Fender well.
2. Take the 3/4-16 Filter Nipple supplied, making sure the shorter end of threads is installed onto the Filter Mount.
3. Using the filter mount as a template, mark and drill three 3/16" holes.
4. Using the #14 Sheet Metal Screws provided, install the Ports-Up Filter Mount onto the vehicle.

Important: The new Filter Mount is designed to accept a 3/4-16 oil filter. Use Derale Part # 13092 or reference Oil Filter Chart above for manufacturers part numbers.

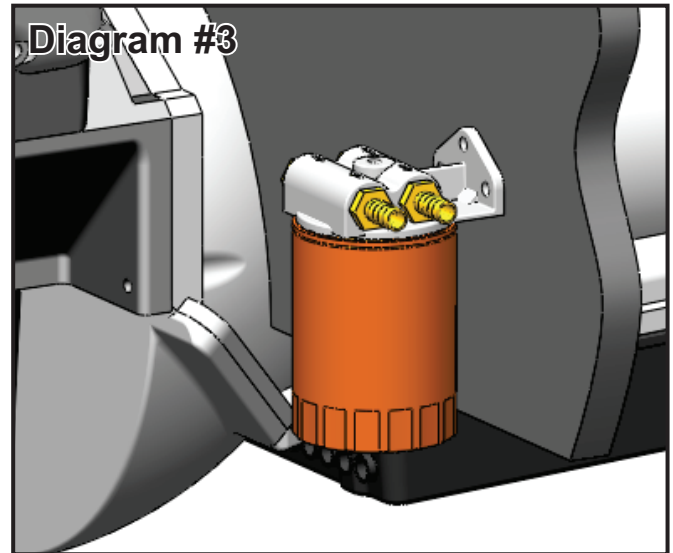

HOSE ROUTING

1. Using the Hose Clamps provided, attach both ends of the 1/2" Hose provided to the hose barbs on the installed Spin-On Adapter forming a loop. (Apply a thin coat of oil to the Hose Barbs so the hose slips on easily.)
2. Carefully route hose over to the Filter Mount.
Note: Keep hoses away from sharp edges, moving parts and exhaust. Do not bend hose sharper than a 5" radius.
3. Cut the hose to the proper length.
4. Using the Hose Clamps provided, attach the hose coming from the OUT on the Spin-On Adapter to the IN on the Filter Mount.
5. Using the Hose Clamps provided, attach the hose coming from the IN on the Spin-On Adapter to the OUT on the Filter Mount.
6. Apply a light coat of oil onto the o-ring of your new oil filter and install on the filter mount.

VEHICLE TESTING

1. Start the engine and quickly check all connections for leaks.
2. Turn-off the engine and check the oil.
3. Add oil as needed.
4. Check oil pressure, if a noticeable pressure drop is identified, then it is possible that the filter is mounted too far from the OE filter landing or there is too much elevation. Make incremental adjustments and re-check oil pressure.

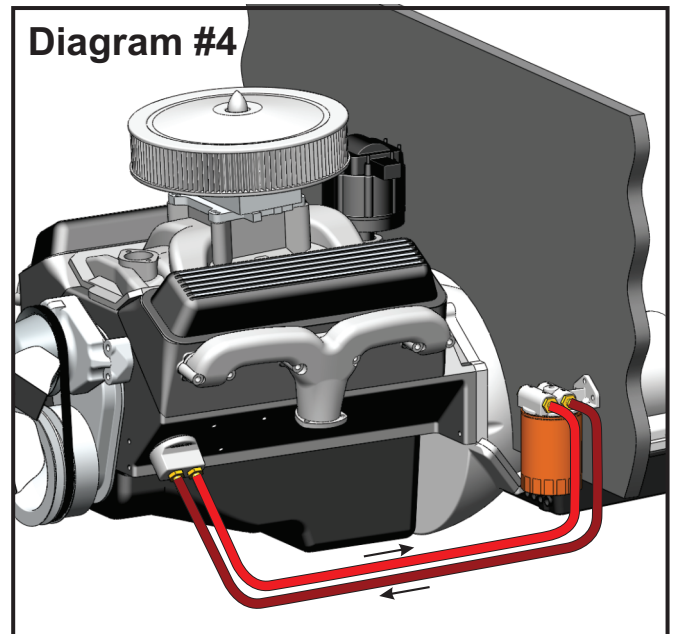

(Page 2)

Warning: Installation of accessories should only be undertaken by those with mechanical knowledge and are familiar with working on vehicles. Always use eye protection (goggles, safety glasses or shield). Park the vehicle in a well lit area, on level ground and apply the parking brake. Only work on a cold vehicle that has been sitting overnight, failure to do so will result in severe burns and injury. Before starting the vehicle, make sure no tools or any other items are left under hood that could interfere with or be drawn into moving parts of the engine. Failure to follow instructions can lead to severe damage and personal injury.